

Image shown may not reflect actual engine

SPECIFICATIONS

V-12, 4-Stroke-Cycle-Diesel

Emissions EPA Tier 2 compliant*, IMO compliant
EU Stage 3A Inland Waterway
accepted as equivalent CCNR Stage II

Displacement 51.8 L (3161 cu. in.)
Rated Engine Speed 1200
Bore 170.0 mm (6.7 in.)
Stroke 190.0 mm (7.48 in.)
Aspiration Turbocharged-Aftercooled
Governor ADEM™ A3
Cooling System Heat Exchanger
Weight, Net Dry
(approx) 6532-7411 kg (14,400-16,340 lb)
Refill Capacity
Cooling System (approx) 156.8 L (41.4 gal)
Lube Oil System 625 L (165 gal)
Oil Change Interval 1000 hr
Caterpillar Diesel Engine Oil 10W30 or 15W40
Deep Sump Oil Pan
Rotation (from flywheel end) Counterclockwise
Flywheel and Flywheel Housing SAE No. 00
Flywheel Teeth 183
3512C Propulsion 512DM62 (standard)
512DM63 (reverse)

A rating

1318 mhp (1300 bhp) 969 kW @ 1200 rpm (DM8714)

B rating

1420 mhp (1400 bhp) 1044 kW @ 1200 rpm (DM8713)

C rating

1521 mhp (1500 bhp) 1118 kW @ 1200 rpm (DM8712)

*EPA Tier 2 certification in process at time of print

STANDARD ENGINE EQUIPMENT

Air Inlet System

Corrosion resistant separate circuit freshwater aftercooled, powercore air cleaner

Control System

Dual Caterpillar® A3 Electronic Control Unit (ECU) LH with electronic unit injector fuel system rigid wiring harness (10 amp DC power required to drive ECU)

Cooling System

Gear-driven centrifugal auxiliary sea water pump, gear-driven centrifugal jacket water pump, expansion tank for commercial engines, coolant shunt tank on lightweight engines, engine oil cooler, thermostats and housing.

ECU Functions

Programmable low idle, SAEJ1939 data link, Cat® data link, engine diagnostics, general alarm relay, programmable parameters (system application and tattletales), Caterpillar ET service tool interface, remote shutdown, shutdown notify, load feedback, overspeed shutdown, overspeed verify

Exhaust System

Dry gas-tight exhaust manifolds with heat shields, dual turbochargers with watercooled bearings and heat shield. Wastegate on select ratings.

Fuel System

Electronically controlled unit injectors, simplex fuel filter (RH) with service indicators, fuel transfer pump

Instrumentation

Marine Power Display of: Engine oil pressure, engine water temperature, fuel pressure, engine speed, fuel consumption, overspeed shutdown notification light, prelube and shutdown override

Lube System

Gear-driven pump, top-mounted dual crankcase breather groups, simplex oil filter, oil filler and dipstick.

Power Take-Offs

Accessory drive, two-sided front housing

Protection System

Emergency stop pushbutton, safety shutoff, oil pressure, and water temperature

General

Two lifting eyes mounted to cylinder heads, Caterpillar yellow paint, parts books and maintenance manuals, shrink-wrap.

ISO Certification

Factory-designed systems built at Caterpillar ISO 9001:2000 certified facilities.

MARINE ENGINE PERFORMANCE

3512C DITA
1318 mhp (1300 bhp) 969 kW @ 1200 rpm
A Rating — DM8714-00

Aftercooler Temperature 48°C (118°F)

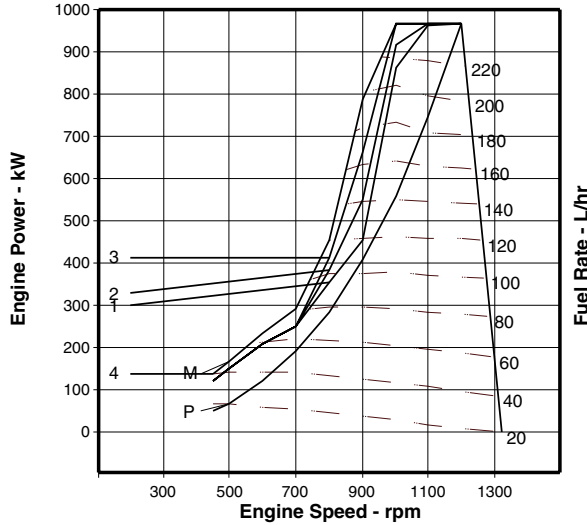

Performance Data

	Speed rpm	Engine Power kW	BSFC g/kW-hr	Fuel Rate L/hr	Boost Press kPa Gauge	Intake Air Flow m³/min	Exh Manif Temp °C	Exh Gas Flow m³/min
Zone Limit	1200	970	211	243.4	245.6	88.3	586	208.5
Curve: 1	1000	865	203	209.0	199.9	66.6	621	166.5
	800	355	223	94.5	43.6	25.2	625	68.6
	700	253	228	68.8	22.1	18.7	573	48.8
	500	150	232	41.4	8.6	13.1	486	30.7
	450	124	236	34.8	6.6	11.1	452	24.7
Zone Limit	1200	970	211	243.4	0.0	88.3	586	208.5
Curve: 2	1000	920	202	221.2	0.0	70.0	627	175.0
	800	384	222	101.8	0.0	26.2	650	73.2
	700	253	228	68.8	0.0	18.7	573	48.8
	500	150	232	41.4	0.0	13.1	486	30.7
	450	124	236	34.8	0.0	11.1	452	24.7
Zone Limit	1200	970	211	243.4	245.6	88.3	586	208.5
Curve: 3	1000	969	201	232.2	230.7	72.9	632	182.9
	800	416	222	109.8	56.4	27.4	675	78.1
	700	253	228	68.8	22.1	18.7	573	48.8
	500	150	232	41.4	8.6	13.1	486	30.7
	450	124	236	34.8	6.6	11.1	452	24.7
Zone Limit	1200	970	211	243.4	245.6	88.3	586	208.5
Curve: 4	1000	970	201	232.3	230.9	72.9	632	182.9
	800	454	221	119.6	65.3	29.0	699	83.9
	700	294	231	81.0	29.4	19.7	645	55.7
	500	167	234	46.6	10.4	13.4	533	32.6
	450	140	238	39.7	8.0	11.2	501	26.1
Max Power	1200	970	211	243.4	245.6	88.3	586	208.5
Curve: M	1000	970	201	232.3	230.9	72.9	632	182.9
	800	454	221	119.6	65.3	29.0	699	83.9
	700	294	231	81.0	29.4	19.7	645	55.7
	500	167	234	46.6	10.4	13.4	533	32.6
	450	140	238	39.7	8.0	11.2	501	26.1
Prop Demand	1200	970	211	243.4	245.6	88.3	586	208.5
Curve: P	1000	561	212	141.9	109.8	46.8	586	116.7
	800	287	226	77.4	31.2	23.2	555	58.5
	700	192	229	52.5	14.4	17.6	464	40.4
	500	70	249	20.8	3.1	12.5	280	21.4
	450	51	264	16.1	1.9	10.6	238	16.8

Brake Mean Effective Pressure 1873 kPa
Heat Rejection to Coolant (total) 380 kW
Heat Rejection to Aftercooler 260 kW
Heat Rejection to Exhaust (total) 861 kW
Heat Rejection to Atmosphere from Engine 114 kW

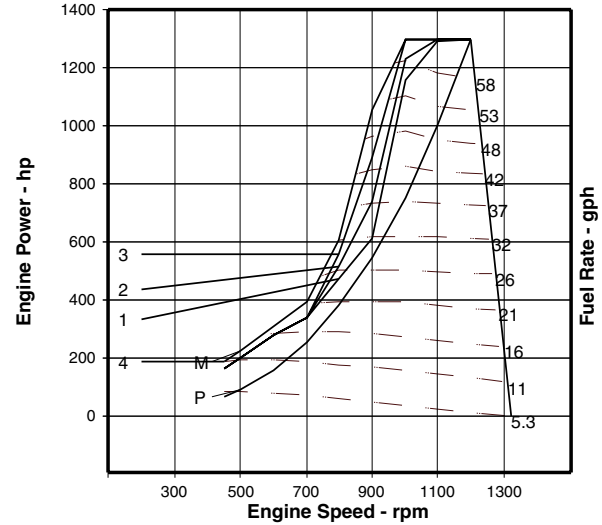

Performance Data

	Speed rpm	Engine Power hp	BSFC lb/hp-hr	Fuel Rate gph	Boost Press in-hg Gauge	Intake Air Flow cfm	Exh Manif Temp °F	Exh Gas Flow cfm
Zone Limit	1200	1301	.347	64.3	72.7	3118	1087	7363
Curve: 1	1000	1160	.334	55.2	59.2	2352	1150	5880
	800	476	.367	25.0	12.9	890	1157	2423
	700	339	.375	18.2	6.5	660	1063	1723
	500	201	.381	10.9	2.5	463	907	1084
	450	166	.388	9.2	2.0	392	846	872
Zone Limit	1200	1301	.347	64.3	0.0	3118	1087	7363
Curve: 2	1000	1234	.332	58.4	0.0	2472	1161	6180
	800	515	.365	26.9	0.0	925	1202	2585
	700	339	.375	18.2	0.0	660	1063	1723
	500	201	.381	10.9	0.0	463	907	1084
	450	166	.388	9.2	0.0	392	846	872
Zone Limit	1200	1301	.347	64.3	72.7	3118	1087	7363
Curve: 3	1000	1299	.330	61.3	68.3	2574	1170	6459
	800	558	.365	29.0	16.7	968	1247	2758
	700	339	.375	18.2	6.5	660	1063	1723
	500	201	.381	10.9	2.5	463	907	1084
	450	166	.388	9.2	2.0	392	846	872
Zone Limit	1200	1301	.347	64.3	72.7	3118	1087	7363
Curve: 4	1000	1301	.330	61.4	68.4	2574	1170	6459
	800	609	.363	31.6	19.3	1024	1290	2963
	700	394	.380	21.4	8.7	696	1193	1967
	500	224	.385	12.3	3.1	473	991	1151
	450	188	.391	10.5	2.4	396	934	922
Max Power	1200	1301	.347	64.3	72.7	3118	1087	7363
Curve: M	1000	1301	.330	61.4	68.4	2574	1170	6459
	800	609	.363	31.6	19.3	1024	1290	2963
	700	394	.380	21.4	8.7	696	1193	1967
	500	224	.385	12.3	3.1	473	991	1151
	450	188	.391	10.5	2.4	396	934	922
Prop Demand	1200	1301	.347	64.3	72.7	3118	1087	7363
Curve: P	1000	752	.349	37.5	32.5	1653	1087	4121
	800	385	.372	20.4	9.2	819	1031	2066
	700	257	.376	13.9	4.3	622	867	1427
	500	94	.409	5.5	0.9	441	536	756
	450	68	.434	4.3	0.6	374	460	593

Brake Mean Effective Pressure 272 psi
Heat Rejection to Coolant (total) 21611 btu/min
Heat Rejection to Aftercooler 14786 btu/min
Heat Rejection to Exhaust (total) 48965 btu/min
Heat Rejection to Atmosphere from Engine 6483 btu/min

MARINE ENGINE PERFORMANCE

3512C DITA

1420 mhp (1400 bhp) 1044 kW @ 1200 rpm
B Rating — DM8713-00

Aftercooler Temperature 48°C (118°F)

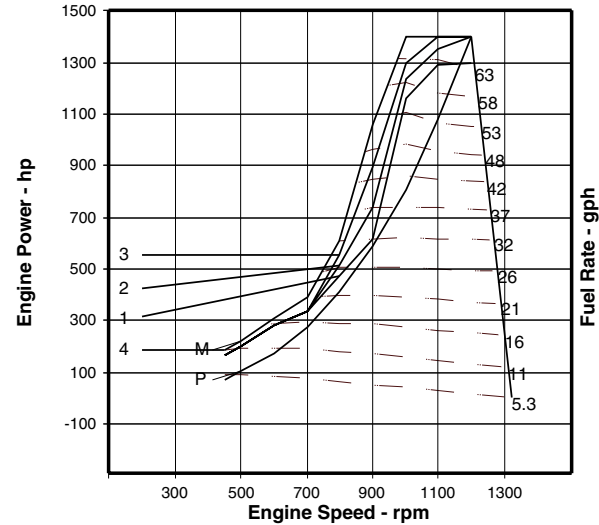
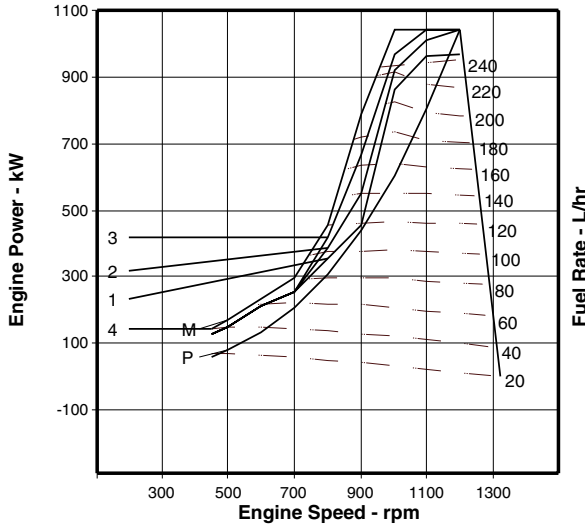

Performance Data

	Engine Speed rpm	Engine Power kW	BSFC g/kWh	Fuel Rate L/hr	Boost Press kPa Gauge	Intake Air Flow m³/min	Exh Manif Temp °C	Exh Gas Flow m³/min
Zone Limit	1200	970	211	243.4	245.6	88.3	586	208.5
Curve: 1	1000	865	203	209.0	199.9	66.6	621	166.5
	800	355	223	94.5	43.6	25.2	625	68.6
	700	253	228	68.8	22.1	18.7	573	48.8
	500	150	232	41.4	8.6	13.1	486	30.7
	450	124	236	34.8	6.6	11.1	452	24.7
Zone Limit	1200	1044	210	261.5	0.0	91.9	603	220.6
Curve: 2	1000	920	202	221.2	0.0	70.0	627	175.0
	800	384	222	101.8	0.0	26.2	650	73.2
	700	253	228	68.8	0.0	18.7	573	48.8
	500	150	232	41.4	0.0	13.1	486	30.7
	450	124	236	34.8	0.0	11.1	452	24.7
Zone Limit	1200	1044	210	261.5	261.6	91.9	603	220.6
Curve: 3	1000	969	201	232.2	230.7	72.9	632	182.9
	800	416	222	109.8	56.4	27.4	675	78.1
	700	253	228	68.8	22.1	18.7	573	48.8
	500	150	232	41.4	8.6	13.1	486	30.7
	450	124	236	34.8	6.6	11.1	452	24.7
Zone Limit	1200	1044	210	261.5	261.6	91.9	603	220.6
Curve: 4	1000	1044	200	248.9	253.6	77.3	639	195.0
	800	454	221	119.6	65.3	29.0	699	83.9
	700	294	231	81.0	29.4	19.7	645	55.7
	500	167	234	46.6	10.4	13.4	533	32.6
	450	140	238	39.7	8.0	11.2	501	26.1
Max Power	1200	1044	210	261.5	261.6	91.9	603	220.6
Curve: M	1000	1044	200	248.9	253.6	77.3	639	195.0
	800	454	221	119.6	65.3	29.0	699	83.9
	700	294	231	81.0	29.4	19.7	645	55.7
	500	167	234	46.6	10.4	13.4	533	32.6
	450	140	238	39.7	8.0	11.2	501	26.1
Prop Demand	1200	1044	210	261.5	261.6	91.9	603	220.6
Curve: P	1000	604	210	151.4	122.7	49.7	592	124.2
	800	309	225	83.0	34.9	23.8	578	61.6
	700	207	228	56.4	16.0	17.9	491	42.3
	500	76	246	22.1	3.4	12.5	293	22.2
	450	55	259	17.0	2.1	10.6	249	17.3

Performance Data

	Engine Speed rpm	Engine Power hp	BSFC lb/hp-hr	Fuel Rate gph	Boost Press in-hg Gauge	Intake Air Flow cfm	Exh Manif Temp °F	Exh Gas Flow cfm
Zone Limit	1200	1301	.347	64.3	72.7	3118	1087	7363
Curve: 1	1000	1160	.334	55.2	59.2	2352	1150	5880
	800	476	.367	25.0	12.9	890	1157	2423
	700	339	.375	18.2	6.5	660	1063	1723
	500	201	.381	10.9	2.5	463	907	1084
	450	166	.388	9.2	2.0	392	846	872
Zone Limit	1200	1400	.345	69.1	0.0	3245	1117	7790
Curve: 2	1000	1234	.332	58.4	0.0	2472	1161	6180
	800	515	.365	26.9	0.0	925	1202	2585
	700	339	.375	18.2	0.0	660	1063	1723
	500	201	.381	10.9	0.0	463	907	1084
	450	166	.388	9.2	0.0	392	846	872
Zone Limit	1200	1400	.345	69.1	77.5	3245	1117	7790
Curve: 3	1000	1299	.330	61.3	68.3	2574	1170	6459
	800	558	.365	29.0	16.7	968	1247	2758
	700	339	.375	18.2	6.5	660	1063	1723
	500	201	.381	10.9	2.5	463	907	1084
	450	166	.388	9.2	2.0	392	846	872
Zone Limit	1200	1400	.345	69.1	77.5	3245	1117	7790
Curve: 4	1000	1400	.329	65.8	75.1	2730	1182	6886
	800	609	.363	31.6	19.3	1024	1290	2963
	700	394	.380	21.4	8.7	696	1193	1967
	500	224	.385	12.3	3.1	473	991	1151
	450	188	.391	10.5	2.4	396	934	922
Max Power	1200	1400	.345	69.1	77.5	3245	1117	7790
Curve: M	1000	1400	.329	65.8	75.1	2730	1182	6886
	800	609	.363	31.6	19.3	1024	1290	2963
	700	394	.380	21.4	8.7	696	1193	1967
	500	224	.385	12.3	3.1	473	991	1151
	450	188	.391	10.5	2.4	396	934	922
Prop Demand	1200	1400	.345	69.1	77.5	3245	1117	7790
Curve: P	1000	810	.345	40.0	36.3	1755	1098	4386
	800	414	.370	21.9	10.3	840	1072	2175
	700	278	.375	14.9	4.7	632	916	1494
	500	102	.404	5.8	1.0	441	559	784
	450	74	.426	4.5	0.6	374	480	611

Brake Mean Effective Pressure 2017 kPa
Heat Rejection to Coolant (total) 400 kW
Heat Rejection to Aftercooler 292 kW
Heat Rejection to Exhaust (total) 922 kW
Heat Rejection to Atmosphere from Engine 119 kW

Brake Mean Effective Pressure 293 psi
Heat Rejection to Coolant (total) 22748 btu/min
Heat Rejection to Aftercooler 16606 btu/min
Heat Rejection to Exhaust (total) 52434 btu/min
Heat Rejection to Atmosphere from Engine 6768 btu/min

MARINE ENGINE PERFORMANCE

3512C DITA
1521 mhp (1500 bhp) 1118 kW @ 1200 rpm
C Rating — DM8712-00

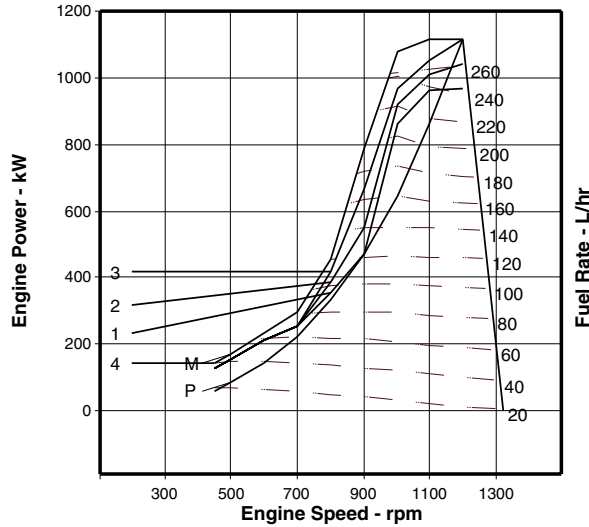

Performance Data

	Engine Speed rpm	Engine Power kW	BSFC g/kW-hr	Fuel Rate L/hr	Boost Press kPa Gauge	Intake Air Flow m³/min	Exh Manif Temp °C	Exh Gas Flow m³/min
Zone Limit	1200	970	211	243.4	245.6	88.3	586	208.5
Curve: 1	1000	865	203	209.0	199.9	66.6	621	166.5
	800	355	223	94.5	43.6	25.2	625	68.6
	700	253	228	68.8	22.1	18.7	573	48.8
	500	150	232	41.4	8.6	13.1	486	30.7
	450	124	236	34.8	6.6	11.1	452	24.7
Zone Limit	1200	1044	210	261.5	0.0	91.9	603	220.6
Curve: 2	1000	920	202	221.2	0.0	70.0	627	175.0
	800	384	222	101.8	0.0	26.2	650	73.2
	700	253	228	68.8	0.0	18.7	573	48.8
	500	150	232	41.4	0.0	13.1	486	30.7
	450	124	236	34.8	0.0	11.1	452	24.7
Zone Limit	1200	1119	210	280.4	276.6	95.3	622	233.1
Curve: 3	1000	969	201	232.2	230.7	72.9	632	182.9
	800	416	222	109.8	56.4	27.4	675	78.1
	700	253	228	68.8	22.1	18.7	573	48.8
	500	150	232	41.4	8.6	13.1	486	30.7
	450	124	236	34.8	6.6	11.1	452	24.7
Zone Limit	1200	1119	210	280.4	276.6	95.3	622	233.1
Curve: 4	1000	1079	200	256.7	264.5	79.3	642	200.8
	800	454	221	119.6	65.3	29.0	699	83.9
	700	294	231	81.0	29.4	19.7	645	55.7
	500	167	234	46.6	10.4	13.4	533	32.6
	450	140	238	39.7	8.0	11.2	501	26.1
Max Power Curve: M	1200	1119	210	280.4	276.6	95.3	622	233.1
	1000	1079	200	256.7	264.5	79.3	642	200.8
	800	454	221	119.6	65.3	29.0	699	83.9
	700	294	231	81.0	29.4	19.7	645	55.7
	500	167	234	46.6	10.4	13.4	533	32.6
	450	140	238	39.7	8.0	11.2	501	26.1
Prop Demand Curve: P	1200	1119	210	280.4	276.6	95.3	622	233.1
	1000	647	209	160.9	135.8	52.6	597	131.6
	800	331	224	88.5	39.0	24.5	602	64.9
	700	222	228	60.3	17.8	18.1	518	44.3
	500	81	243	23.4	3.7	12.6	307	22.9
	450	59	256	18.0	2.3	10.6	260	17.9

Brake Mean Effective Pressure	2017 kPa
Heat Rejection to Coolant (total)	421 kW
Heat Rejection to Aftercooler	325 kW
Heat Rejection to Exhaust (total)	988 kW
Heat Rejection to Atmosphere from Engine	125 kW

Aftercooler Temperature 48°C (118°F)

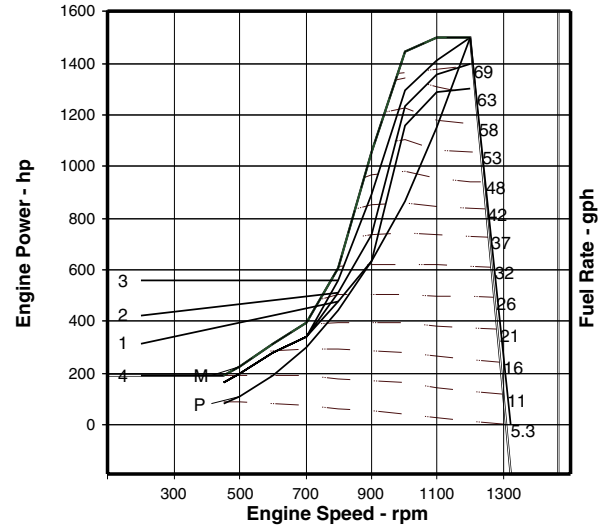

Performance Data

	Engine Speed rpm	Engine Power hp	BSFC lb/hp-hr	Fuel Rate gph	Boost Press in-hg Gauge	Intake Air Flow cfm	Exh Manif Temp °F	Exh Gas Flow cfm
Zone Limit	1200	1301	.347	64.3	72.7	3118	1087	7363
Curve: 1	1000	1160	.334	55.2	59.2	2352	1150	5880
	800	476	.367	25.0	12.9	890	1157	2423
	700	339	.375	18.2	6.5	660	1063	1723
	500	201	.381	10.9	2.5	463	907	1084
	450	166	.388	9.2	2.0	392	846	872
Zone Limit	1200	1400	.345	69.1	0.0	3245	1117	7790
Curve: 2	1000	1234	.332	58.4	0.0	2472	1161	6180
	800	515	.365	26.9	0.0	925	1202	2585
	700	339	.375	18.2	0.0	660	1063	1723
	500	201	.381	10.9	0.0	463	907	1084
	450	166	.388	9.2	0.0	392	846	872
Zone Limit	1200	1501	.345	74.1	81.9	3365	1152	8232
Curve: 3	1000	1299	.330	61.3	68.3	2574	1170	6459
	800	558	.365	29.0	16.7	968	1247	2758
	700	339	.375	18.2	6.5	660	1063	1723
	500	201	.381	10.9	2.5	463	907	1084
	450	166	.388	9.2	2.0	392	846	872
Zone Limit	1200	1501	.345	74.1	81.9	3365	1152	8232
Curve: 4	1000	1447	.329	67.8	78.3	2800	1188	7091
	800	609	.363	31.6	19.3	1024	1290	2963
	700	394	.380	21.4	8.7	696	1193	1967
	500	224	.385	12.3	3.1	473	991	1151
	450	188	.391	10.5	2.4	396	934	922
Max Power Curve: M	1200	1501	.345	74.1	81.9	3365	1152	8232
	1000	1447	.329	67.8	78.3	2800	1188	7091
	800	609	.363	31.6	19.3	1024	1290	2963
	700	394	.380	21.4	8.7	696	1193	1967
	500	224	.385	12.3	3.1	473	991	1151
	450	188	.391	10.5	2.4	396	934	922
Prop Demand Curve: P	1200	1501	.345	74.1	81.9	3365	1152	8232
	1000	868	.344	42.5	40.2	1858	1107	4647
	800	444	.368	23.4	11.5	865	1116	2292
	700	298	.375	15.9	5.3	639	964	1564
	500	109	.399	6.2	1.1	445	585	809
	450	79	.421	4.8	0.7	374	500	632

Brake Mean Effective Pressure	293 psi
Heat Rejection to Coolant (total)	23942 btu/min
Heat Rejection to Aftercooler	18483 btu/min
Heat Rejection to Exhaust (total)	56187 btu/min
Heat Rejection to Atmosphere from Engine	7109 btu/min

DIMENSIONS

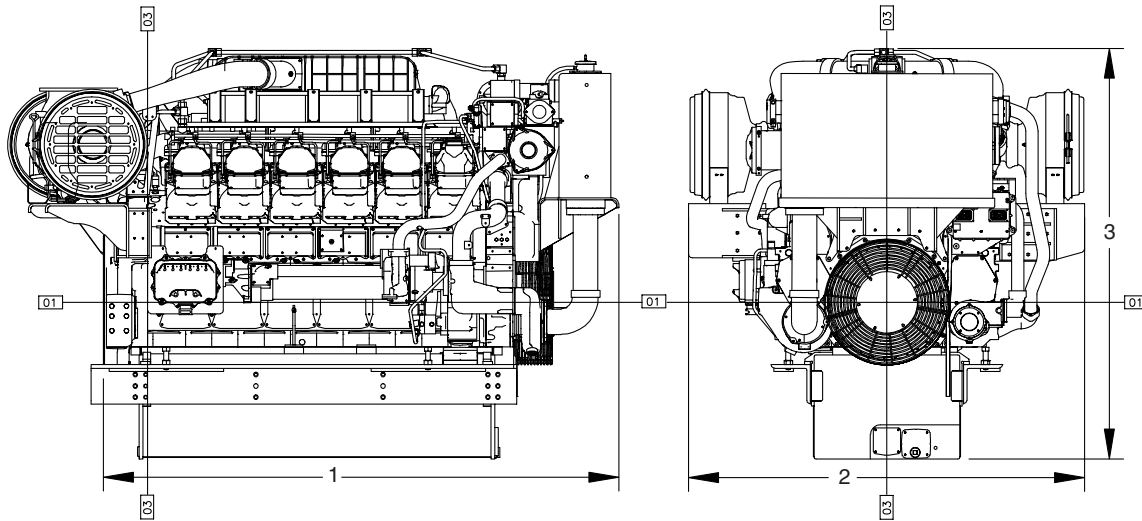

Engine Dimensions		
(1) Length to Flywheel Housing	2625.4 mm	103.4 in.
(2) Width	2036.9 mm	80.19 in.
(3) Height	2113.3 mm	83.2 in.
Weight, Net Dry (approx)	6532-7411 kg	14,400-16,340 lb

Note: Do not use for installation design. See general dimension drawings for detail (#340-3586, #340-3585).

For most current installation drawings, please visit <http://tmi.cat.com>

RATING DEFINITIONS AND CONDITIONS

A Rating (Unrestricted Continuous)

Typical applications: For vessels operating at rated load and rated speed up to 100% of the time without interruption or load cycling (80% to 100% load factor). Typical applications could include but are not limited to vessels such as freighters, tugboats, bottom trawlers, or deep river tugboats. Typical operation ranges from 5000 to 8000 hours per year.

B Rating (Heavy Duty)

Typical applications: For vessels operating at rated load and rated speed up to 80% of the time, or 10 hours out of 12, with some load cycling (40% to 80% load factor). Typical applications could include but are not limited to vessels such as mid-water trawlers, purse seiner, crew and supply boats, ferries, or towboats. Typical operation ranges from 3000 to 5000 hours per year.

C Rating (Maximum Continuous)

Typical applications: For vessels operating at rated load and rated speed up to 50% of the time, or 6 hours out of 12, with cyclical load and speed (20% to 80% load

factor). Typical applications could include but are not limited to vessels such as ferries, harbor tugs, fishing boats, offshore service boats, displacement hull yachts, or short trip coastal freighters. Typical operation ranges from 2000 to 4000 hours per year.

Power at declared engine speed is in accordance with ISO3046-1:2002E. Caterpillar maintains ISO9001:1994/QS-9000 approved engine test facilities to assure accurate calibration of test equipment. Electronically controlled engines are set at the factory at the advertised power corrected to standard ambient conditions. The published fuel consumption rates are in accordance with ISO3046-1.

Fuel rates are based on fuel oil of 35° API [16°C (60°F)] gravity having an LHV of 42 780 kJ/kg (18,390 Btu/lb) when used at 29°C (85°F) and weighing 838.9 g/L (7.001 lb/U.S. gal). Additional ratings may be available for specific customer requirements. Consult your Caterpillar representative for additional information.

Performance data is calculated in accordance with tolerances and conditions stated in this specification sheet and is only intended for purposes of comparison with other manufacturers' engines. Actual engine performance may vary according to the particular application of the engine and operating conditions beyond Caterpillar's control.

Power produced at the flywheel will be within standard tolerances up to 50°C (122°F) combustion air temperature measured at the air cleaner inlet, and fuel temperature up to 52°C (125°F) measured at the fuel filter base. Power rated in accordance with NMMA procedure as crankshaft power. Reduce crankshaft power by 3% for propeller shaft power.

CAT, CATERPILLAR, their respective logos, ADEM, "Caterpillar Yellow" and the POWER EDGE trade dress, as well as corporate and product identity used herein, are trademarks of Caterpillar and may not be used without permission.

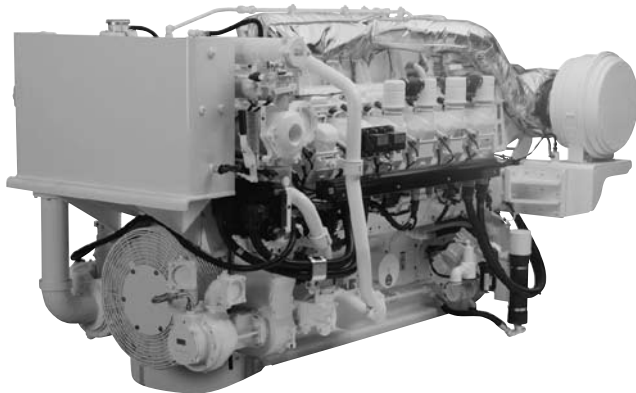

Image shown may not reflect actual engine

SPECIFICATIONS

V-12, 4-Stroke-Cycle-Diesel

Emissions EPA Tier 2 compliant*, IMO compliant
EU Stage 3A Inland Waterway
accepted as equivalent CCNR Stage II

Displacement 58.56 L (3574 cu. in.)

Rated Engine Speed 1200

Bore 170.0 mm (6.7 in.)

Stroke 215 mm (8.46 in.)

Aspiration Twin Turbocharged-Aftercooled Governor ADEM™ A3

Cooling System Heat Exchanger

Weight, Net Dry
(approx) 6532-7411 kg (14,400-16,340 lb)

Refill Capacity

Cooling System (approx) 156.8 L (41.4 gal)

Lube Oil System 625 L (165 gal)

Oil Change Interval 1000 hr
Caterpillar Diesel Engine Oil 10W30 or 15W40
Deep Sump Oil Pan

Rotation (from flywheel end) Counterclockwise

Flywheel and Flywheel Housing SAE No. 00

Flywheel Teeth 183

3512C HD Propulsion 512DM54 (standard)
512DM54 (reverse)

A rating

1521 mhp (1500 bhp) 1118 kW @ 1200 rpm (DM8730)

B rating

1622 mhp (1600 bhp) 1194 kW @ 1200 rpm (DM8731)

C rating

1723 mhp (1700 bhp) 1268 kW @ 1200 rpm (DM8732)

*EPA Tier 2 certification in process at time of print

STANDARD ENGINE EQUIPMENT

Air Inlet System

Corrosion resistant separate circuit freshwater aftercooled, powercore air cleaner

Control System

Dual Caterpillar® A3 Electronic Control Unit (ECU) LH with electronic unit injector fuel system rigid wiring harness (10 amp DC power required to drive ECU)

Cooling System

Gear-driven centrifugal auxiliary sea water pump, gear-driven centrifugal jacket water pump, expansion tank for commercial engines, coolant shunt tank on lightweight engines, engine oil cooler, thermostats and housing.

ECU Functions

Programmable low idle, SAEJ1939 data link, Cat® data link, engine diagnostics, general alarm relay, programmable parameters (system application and tattletales), Caterpillar ET service tool interface, remote shutdown, shutdown notify, load feedback, overspeed shutdown, overspeed verify

Exhaust System

Dry gas-tight exhaust manifolds with heat shields, dual turbochargers with watercooled bearings and heat shield. Wastegate on select ratings.

Fuel System

Electronically controlled unit injectors, simplex fuel filter with service indicators, fuel transfer pump

Instrumentation

Marine Power Display of: Engine oil pressure, engine water temperature, fuel pressure, engine speed, fuel consumption, overspeed shutdown notification light, prelube and shutdown override

Lube System

Gear-driven pump, top-mounted dual crankcase breather groups, simplex oil filter, oil filler and dipstick.

Power Take-Offs

Accessory drive, two-sided front housing

Protection System

Emergency stop pushbutton, safety shutoff, oil pressure, and water temperature

General

Two lifting eyes mounted to cylinder heads, Caterpillar yellow paint, parts books and maintenance manuals, shrink-wrap.

ISO Certification

Factory-designed systems built at Caterpillar ISO 9001:2000 certified facilities.

MARINE ENGINE PERFORMANCE

3512C HD

1521 mhp (1500 bhp) 1118 kW @ 1200 rpm

A Rating — DM8730-00

Aftercooler Temperature 43°C (109°F)

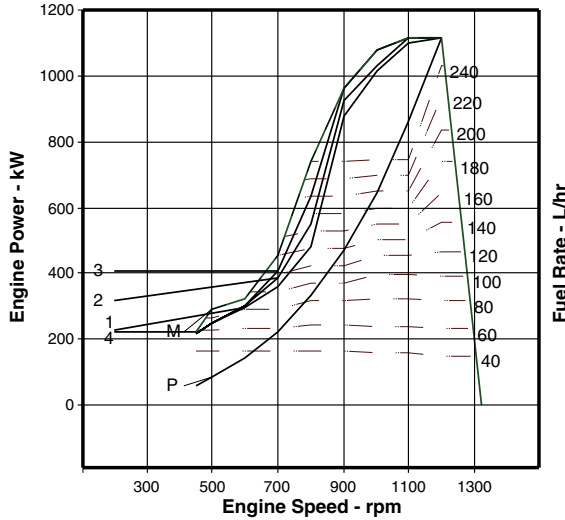

Performance Data

	Engine Speed rpm	Power kW	BSFC g/kW-hr	Fuel Rate L/hr	Boost Press kPa Gauge	Intake Air Flow m³/min	Exh Manif Temp °C	Exh Gas Flow m³/min
Zone Limit	1200	1119	203	270.6	259.4	104.7	554	230.6
Curve: 1	1000	1015	197	238.0	232.0	81.6	578	193.4
	800	481	215	123.5	72.0	33.7	625	92.4
	700	360	209	89.6	42.6	24.6	625	68.2
	500	247	222	65.4	21.3	15.0	614	40.9
	450	215	220	56.1	17.3	13.2	567	33.9
Zone Limit	1200	1119	203	270.6	0.0	104.7	554	230.6
Curve: 2	1000	1032	196	241.4	0.0	82.6	580	195.9
	800	549	213	139.1	0.0	36.3	650	102.1
	700	388	212	98.1	0.0	25.4	650	72.2
	500	247	222	65.4	0.0	15.0	614	40.9
	450	215	220	56.1	0.0	13.2	567	33.9
Zone Limit	1200	1119	203	270.6	259.4	104.7	554	230.6
Curve: 3	1000	1080	196	251.9	248.5	85.5	586	203.8
	800	635	209	157.9	106.1	40.3	675	115.2
	700	409	215	104.7	51.5	26.1	667	75.1
	500	247	222	65.4	21.3	15.0	614	40.9
	450	215	220	56.1	17.3	13.2	567	33.9
Zone Limit	1200	1119	203	270.6	259.4	104.7	554	230.6
Curve: 4	1000	1080	196	251.9	248.5	85.5	586	203.8
	800	741	204	179.9	134.9	46.1	698	132.7
	700	454	223	120.7	60.5	27.7	697	81.5
	500	291	232	80.6	29.8	16.0	727	48.4
	450	222	224	59.2	18.2	13.3	579	34.5
Max Power	1200	1119	203	270.6	259.4	104.7	554	230.6
Curve: M	1000	1080	196	251.9	248.5	85.5	586	203.8
	800	741	204	179.9	134.9	46.1	698	132.7
	700	454	223	120.7	60.5	27.7	697	81.5
	500	291	232	80.6	29.8	16.0	727	48.4
	450	222	224	59.2	18.2	13.3	579	34.5
Prop Demand	1200	1119	203	270.6	259.4	104.7	554	230.6
Curve: P	1000	647	206	159.2	139.8	59.3	533	137.2
	800	331	212	83.7	46.8	28.9	545	72.2
	700	222	213	56.3	22.3	21.2	459	48.7
	500	81	213	20.5	6.3	13.5	261	23.2
	450	59	232	16.3	4.7	12.1	215	19.0

Brake Mean Effective Pressure	1910 kPa
Heat Rejection to Coolant (total)	426 kW
Heat Rejection to Aftercooler	312 kW
Heat Rejection to Exhaust (total)	914 kW
Heat Rejection to Atmosphere from Engine	104 kW

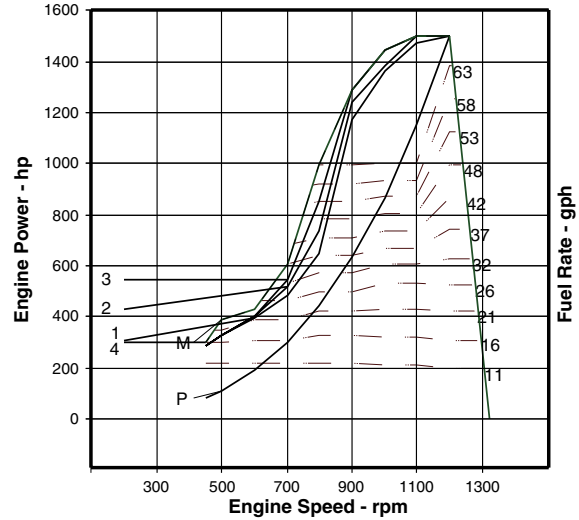

Performance Data

	Engine Speed rpm	Power hp	BSFC lb/hp-hr	Fuel Rate gph	Boost Press in-hg Gauge	Intake Air Flow cfm	Exh Manif Temp °F	Exh Gas Flow cfm
Zone Limit	1200	1501	.334	71.5	76.8	3697	1029	8144
Curve: 1	1000	1361	.324	62.9	68.7	2882	1072	6830
	800	645	.353	32.6	21.3	1190	1157	3263
	700	483	.344	23.7	12.6	869	1157	2408
	500	331	.365	17.3	6.3	530	1137	1444
	450	288	.362	14.8	5.1	466	1053	1197
Zone Limit	1200	1501	.334	71.5	0.0	3697	1029	8144
Curve: 2	1000	1384	.322	63.8	0.0	2917	1076	6918
	800	736	.350	36.7	0.0	1282	1202	3606
	700	520	.349	25.9	0.0	897	1202	2550
	500	331	.365	17.3	0.0	530	1137	1444
	450	288	.362	14.8	0.0	466	1053	1197
Zone Limit	1200	1501	.334	71.5	76.8	3697	1029	8144
Curve: 3	1000	1448	.322	66.5	73.6	3019	1087	7197
	800	852	.344	41.7	31.4	1423	1247	4068
	700	548	.353	27.7	15.3	922	1233	2652
	500	331	.365	17.3	6.3	530	1137	1444
	450	288	.362	14.8	5.1	466	1053	1197
Zone Limit	1200	1501	.334	71.5	76.8	3697	1029	8144
Curve: 4	1000	1448	.322	66.5	73.6	3019	1087	7197
	800	994	.335	47.5	39.9	1628	1288	4686
	700	609	.367	31.9	17.9	978	1287	2878
	500	390	.381	21.3	8.8	565	1341	1709
	450	298	.368	15.6	5.4	470	1074	1218
Max Power	1200	1501	.334	71.5	76.8	3697	1029	8144
Curve: M	1000	1448	.322	66.5	73.6	3019	1087	7197
	800	994	.335	47.5	39.9	1628	1288	4686
	700	609	.367	31.9	17.9	978	1287	2878
	500	390	.381	21.3	8.8	565	1341	1709
	450	298	.368	15.6	5.4	470	1074	1218
Prop Demand	1200	1501	.334	71.5	76.8	3697	1029	8144
Curve: P	1000	868	.339	42.1	41.4	2094	991	4845
	800	444	.349	22.1	13.9	1021	1013	2550
	700	298	.350	14.9	6.6	749	858	1720
	500	109	.350	5.4	1.9	477	502	819
	450	79	.381	4.3	1.4	427	419	671

Brake Mean Effective Pressure	277 psi
Heat Rejection to Coolant (total)	24227 btu/min
Heat Rejection to Aftercooler	17743 btu/min
Heat Rejection to Exhaust (total)	51979 btu/min
Heat Rejection to Atmosphere from Engine	5914 btu/min

MARINE ENGINE PERFORMANCE

3512C HD

1622 mhp (1600 bhp) 1194 kW @ 1200 rpm

B Rating — DM8731-00

Aftercooler Temperature 43°C (109°F)

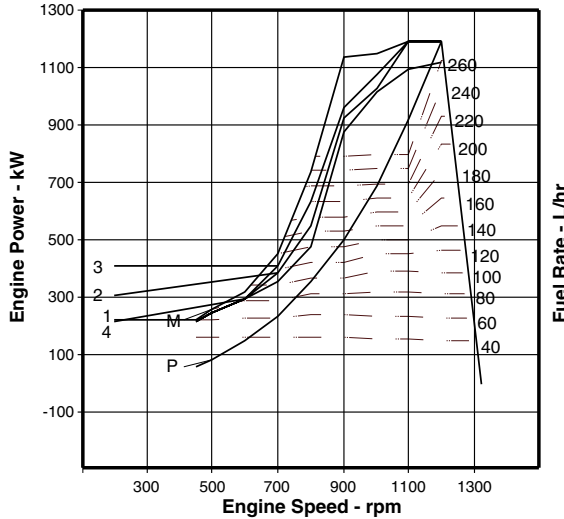

Performance Data

	Engine Speed rpm	Engine Power kW	BSFC g/kW-hr	Fuel Rate L/hr	Boost Press kPa Gauge	Intake Air Flow m³/min	Exh Manif Temp °C	Exh Gas Flow m³/min
Zone Limit	1200	1119	203	270.6	259.4	104.7	554	230.6
Curve: 1	1000	1015	197	238.0	232.0	81.6	578	193.4
	800	481	215	123.5	72.0	33.7	625	92.4
	700	360	209	89.6	42.6	24.6	625	68.2
	500	247	222	65.4	21.3	15.0	614	40.9
	450	215	220	56.1	17.3	13.2	567	33.9
Zone Limit	1200	1193	203	288.3	0.0	106.5	572	242.2
Curve: 2	1000	1032	196	241.4	0.0	82.6	580	195.9
	800	549	213	139.1	0.0	36.3	650	102.1
	700	388	212	98.1	0.0	25.4	650	72.2
	500	247	222	65.4	0.0	15.0	614	40.9
	450	215	220	56.1	0.0	13.2	567	33.9
Zone Limit	1200	1193	203	288.3	270.8	106.5	572	242.2
Curve: 3	1000	1080	196	251.9	248.5	85.5	586	203.8
	800	635	209	157.9	106.1	40.3	675	115.2
	700	409	215	104.7	51.5	26.1	667	75.1
	500	247	222	65.4	21.3	15.0	614	40.9
	450	215	220	56.1	17.3	13.2	567	33.9
Zone Limit	1200	1193	203	288.3	270.8	106.5	572	242.2
Curve: 4	1000	1150	196	268.2	268.2	90.3	594	216.3
	800	741	204	179.9	134.9	46.1	698	132.7
	700	454	223	120.7	60.5	27.7	697	81.5
	500	263	226	70.6	24.0	15.3	652	43.4
	450	222	224	59.2	18.2	13.3	579	34.5
Max Power	1200	1193	203	288.3	270.8	106.5	572	242.2
Curve: M	1000	1150	196	268.2	268.2	90.3	594	216.3
	800	741	204	179.9	134.9	46.1	698	132.7
	700	454	223	120.7	60.5	27.7	697	81.5
	500	263	226	70.6	24.0	15.3	652	43.4
	450	222	224	59.2	18.2	13.3	579	34.5
Prop Demand	1200	1193	203	288.3	270.8	106.5	572	242.2
Curve: P	1000	690	206	169.3	152.2	62.4	539	144.6
	800	354	213	89.7	50.5	29.6	561	75.3
	700	237	212	59.8	24.1	21.5	480	50.8
	500	86	213	21.9	6.6	13.5	273	23.7
	450	63	231	17.3	4.9	12.1	224	19.4

Brake Mean Effective Pressure	2037 kPa
Heat Rejection to Coolant (total)	446 kW
Heat Rejection to Aftercooler	339 kW
Heat Rejection to Exhaust (total)	980 kW
Heat Rejection to Atmosphere from Engine	106 kW

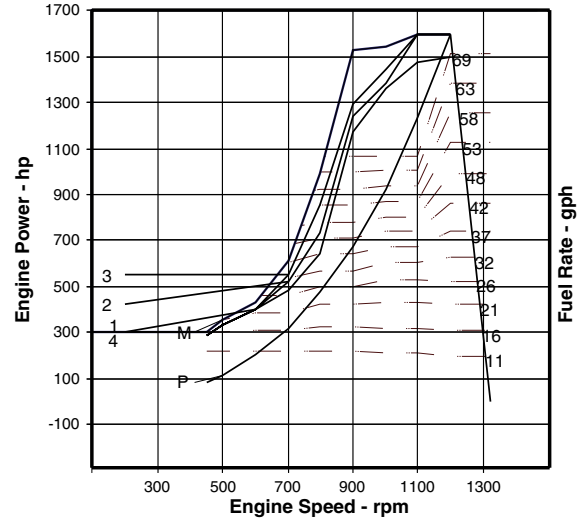

Performance Data

	Engine Speed rpm	Engine Power hp	BSFC lb/hp-hr	Fuel Rate gph	Boost Press in-hg Gauge	Intake Air Flow cfm	Exh Manif Temp °F	Exh Gas Flow cfm
Zone Limit	1200	1501	.334	71.5	76.8	3697	1029	8144
Curve: 1	1000	1361	.324	62.9	68.7	2882	1072	6830
	800	645	.353	32.6	21.3	1190	1157	3263
	700	483	.344	23.7	12.6	869	1157	2408
	500	331	.365	17.3	6.3	530	1137	1444
	450	288	.362	14.8	5.1	466	1053	1197
Zone Limit	1200	1600	.334	76.2	0.0	3761	1062	8553
Curve: 2	1000	1384	.322	63.8	0.0	2917	1076	6918
	800	736	.350	36.7	0.0	1282	1202	3606
	700	520	.349	25.9	0.0	897	1202	2550
	500	331	.365	17.3	0.0	530	1137	1444
	450	288	.362	14.8	0.0	466	1053	1197
Zone Limit	1200	1600	.334	76.2	80.2	3761	1062	8553
Curve: 3	1000	1448	.322	66.5	73.6	3019	1087	7197
	800	852	.344	41.7	31.4	1423	1247	4068
	700	548	.353	27.7	15.3	922	1233	2652
	500	331	.365	17.3	6.3	530	1137	1444
	450	288	.362	14.8	5.1	466	1053	1197
Zone Limit	1200	1600	.334	76.2	80.2	3761	1062	8553
Curve: 4	1000	1542	.322	70.9	79.4	3189	1101	7639
	800	994	.335	47.5	39.9	1628	1288	4686
	700	609	.367	31.9	17.9	978	1287	2878
	500	353	.372	18.7	7.1	540	1206	1533
	450	298	.368	15.6	5.4	470	1074	1218
Max Power	1200	1600	.334	76.2	80.2	3761	1062	8553
Curve: M	1000	1542	.322	70.9	79.4	3189	1101	7639
	800	994	.335	47.5	39.9	1628	1288	4686
	700	609	.367	31.9	17.9	978	1287	2878
	500	353	.372	18.7	7.1	540	1206	1533
	450	298	.368	15.6	5.4	470	1074	1218
Prop Demand	1200	1600	.334	76.2	80.2	3761	1062	8553
Curve: P	1000	925	.339	44.7	45.1	2204	1002	5107
	800	475	.350	23.7	15.0	1045	1042	2659
	700	318	.349	15.8	7.1	759	896	1794
	500	115	.350	5.8	2.0	477	523	837
	450	84	.380	4.6	1.5	427	435	685

Brake Mean Effective Pressure	295 psi
Heat Rejection to Coolant (total)	25364 btu/min
Heat Rejection to Aftercooler	19279 btu/min
Heat Rejection to Exhaust (total)	55732 btu/min
Heat Rejection to Atmosphere from Engine	6028 btu/min

MARINE ENGINE PERFORMANCE

3512C HD

1723 mhp (1700 bhp) 1268 kW @ 1200 rpm

C Rating — DM8732-00

Aftercooler Temperature 43°C (109°F)

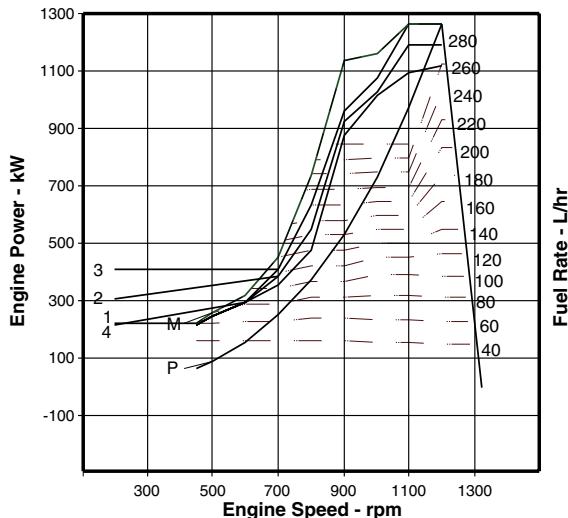

Performance Data

	Engine Speed rpm	Engine Power kW	BSFC g/kW-hr	Fuel Rate L/hr	Boost Press kPa Gauge	Intake Air Flow m³/min	Exh Manif Temp °C	Exh Gas Flow m³/min
Zone	1200	1119	203	270.6	259.4	104.7	554	230.6
Limit	1000	1015	197	238.0	232.0	81.6	578	193.4
Curve: 1	800	481	215	123.5	72.0	33.7	625	92.4
	700	360	209	89.6	42.6	24.6	625	68.2
	500	247	222	65.4	21.3	15.0	614	40.9
	450	215	220	56.1	17.3	13.2	567	33.9
Zone	1200	1193	203	288.3	0.0	106.5	572	242.2
Limit	1000	1032	196	241.4	0.0	82.6	580	195.9
Curve: 2	800	549	213	139.1	0.0	36.3	650	102.1
	700	388	212	98.1	0.0	25.4	650	72.2
	500	247	222	65.4	0.0	15.0	614	40.9
	450	215	220	56.1	0.0	13.2	567	33.9
Zone	1200	1268	204	308.3	281.7	108.2	596	256.2
Limit	1000	1080	196	271.4	272.0	91.3	596	218.7
Curve: 3	800	635	209	157.9	106.1	40.3	675	115.2
	700	409	215	104.7	51.5	26.1	667	75.1
	500	247	222	65.4	21.3	15.0	614	40.9
	450	215	220	56.1	17.3	13.2	567	33.9
Zone	1200	1268	204	308.3	281.7	108.2	596	256.2
Limit	1000	1163	196	271.4	272.0	91.3	596	218.7
Curve: 4	800	741	204	179.9	134.9	46.1	698	132.7
	700	454	223	120.7	60.5	27.7	697	81.5
	500	263	226	70.6	24.0	15.3	652	43.4
	450	222	224	59.2	18.2	13.3	579	34.5
Max Power	1200	1268	204	308.3	281.7	108.2	596	256.2
Limit	1000	1163	196	271.4	272.0	91.3	596	218.7
Curve: M	800	741	204	179.9	134.9	46.1	698	132.7
	700	454	223	120.7	60.5	27.7	697	81.5
	500	263	226	70.6	24.0	15.3	652	43.4
	450	222	224	59.2	18.2	13.3	579	34.5
Prop Demand	1200	1268	204	308.3	281.7	108.2	596	256.2
Limit	1000	734	205	179.4	164.2	65.4	545	151.7
Curve: P	800	376	214	96.0	54.0	30.3	575	78.3
	700	252	211	63.4	26.0	21.8	502	52.8
	500	92	214	23.4	7.0	13.5	285	24.3
	450	67	230	18.3	5.2	12.2	234	19.7

Brake Mean Effective Pressure	2037 kPa
Heat Rejection to Coolant (total)	468 kW
Heat Rejection to Aftercooler	366 kW
Heat Rejection to Exhaust (total)	1066 kW
Heat Rejection to Atmosphere from Engine	107 kW

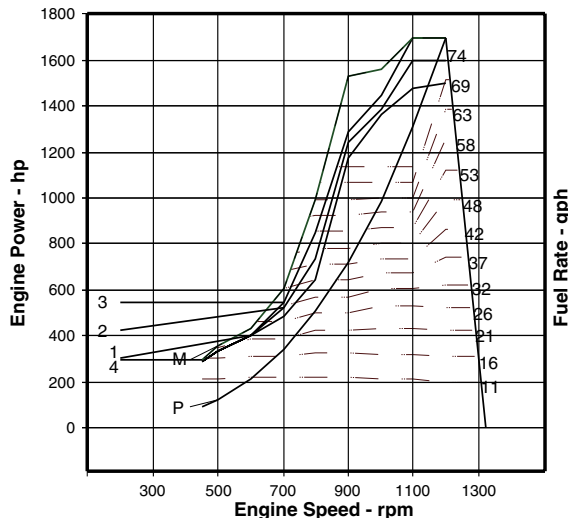

Performance Data

	Engine Speed rpm	Engine Power hp	BSFC lb/hp-hr	Fuel Rate gph	Boost Press in-hg Gauge	Intake Air Flow cfm	Exh Manif Temp °F	Exh Gas Flow cfm
Zone	1200	1501	.334	71.5	76.8	3697	1029	8144
Limit	1000	1361	.324	62.9	68.7	2882	1072	6830
Curve: 1	800	645	.353	32.6	21.3	1190	1157	3263
	700	483	.344	23.7	12.6	869	1157	2408
	500	331	.365	17.3	6.3	530	1137	1444
	450	288	.362	14.8	5.1	466	1053	1197
Zone	1200	1600	.334	76.2	0.0	3761	1062	8553
Limit	1000	1384	.322	63.8	0.0	2917	1076	6918
Curve: 2	800	736	.350	36.7	0.0	1282	1202	3606
	700	520	.349	25.9	0.0	897	1202	2550
	500	331	.365	17.3	0.0	530	1137	1444
	450	288	.362	14.8	0.0	466	1053	1197
Zone	1200	1700	.335	81.4	83.4	3821	1105	9048
Limit	1000	1448	.322	66.5	73.6	3019	1087	7197
Curve: 3	800	852	.344	41.7	31.4	1423	1247	4068
	700	548	.353	27.7	15.3	922	1233	2652
	500	331	.365	17.3	6.3	530	1137	1444
	450	288	.362	14.8	5.1	466	1053	1197
Zone	1200	1700	.335	81.4	83.4	3821	1105	9048
Limit	1000	1560	.322	71.7	80.5	3224	1105	7723
Curve: 4	800	994	.335	47.5	39.9	1628	1288	4686
	700	609	.367	31.9	17.9	978	1287	2878
	500	353	.372	18.7	7.1	540	1206	1533
	450	298	.368	15.6	5.4	470	1074	1218
Max Power	1200	1700	.335	81.4	83.4	3821	1105	9048
Limit	1000	1560	.322	71.7	80.5	3224	1105	7723
Curve: M	800	994	.335	47.5	39.9	1628	1288	4686
	700	609	.367	31.9	17.9	978	1287	2878
	500	353	.372	18.7	7.1	540	1206	1533
	450	298	.368	15.6	5.4	470	1074	1218
Prop Demand	1200	1700	.335	81.4	83.4	3821	1105	9048
Limit	1000	984	.337	47.4	48.6	2310	1013	5357
Curve: P	800	504	.352	25.4	16.0	1070	1067	2765
	700	338	.347	16.7	7.7	770	936	1865
	500	123	.352	6.2	2.1	477	545	858
	450	90	.378	4.8	1.5	431	453	696

Brake Mean Effective Pressure	295 psi
Heat Rejection to Coolant (total)	26615 btu/min
Heat Rejection to Aftercooler	20814 btu/min
Heat Rejection to Exhaust (total)	60623 btu/min
Heat Rejection to Atmosphere from Engine	6085 btu/min

DIMENSIONS

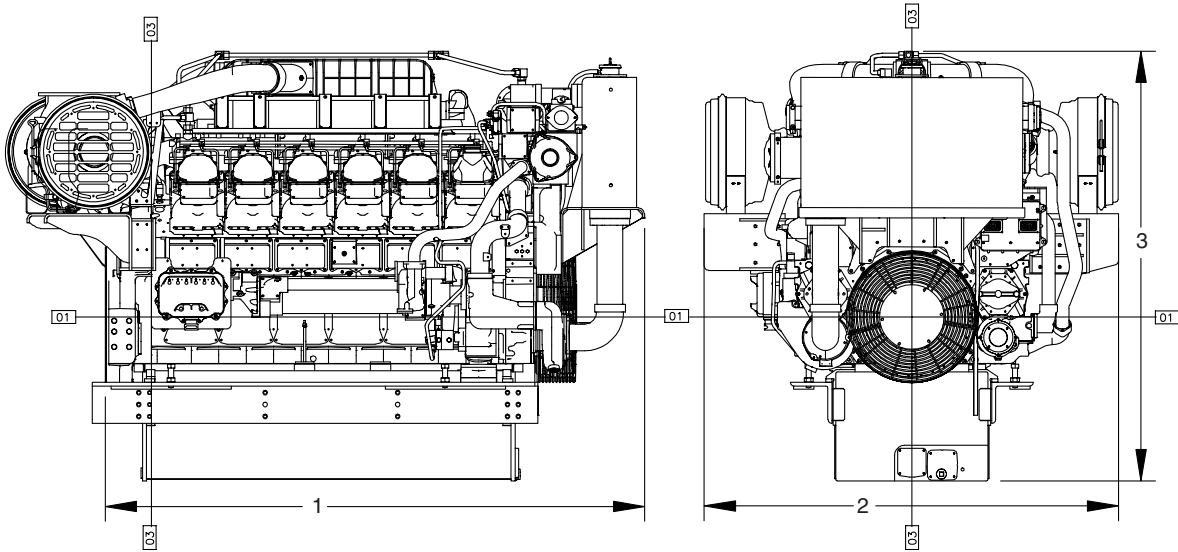

Engine Dimensions		
(1) Length to Flywheel Housing	2644.1 mm	104.1 in.
(2) Width	2036.9 mm	80.19 in.
(3) Height	2113.3 mm	83.2 in.
Weight, Net Dry (approx)	6532-7411 kg	14,400-16,340 lb

Note: Do not use for installation design. See general dimension drawings for detail (#313-1383, #310-3268).

For most current installation drawings, please visit <http://tmi.cat.com>

RATING DEFINITIONS AND CONDITIONS

A Rating (Unrestricted Continuous)

Typical applications: For vessels operating at rated load and rated speed up to 100% of the time without interruption or load cycling (80% to 100% load factor). Typical applications could include but are not limited to vessels such as freighters, tugboats, bottom trawlers, or deep river tugboats. Typical operation ranges from 5000 to 8000 hours per year.

B Rating (Heavy Duty)

Typical applications: For vessels operating at rated load and rated speed up to 80% of the time, or 10 hours out of 12, with some load cycling (40% to 80% load factor). Typical applications could include but are not limited to vessels such as mid-water trawlers, purse seiner, crew and supply boats, ferries, or towboats. Typical operation ranges from 3000 to 5000 hours per year.

C Rating (Maximum Continuous)

Typical applications: For vessels operating at rated load and rated speed up to 50% of the time, or 6 hours out of 12, with cyclical load and speed (20% to 80% load

factor). Typical applications could include but are not limited to vessels such as ferries, harbor tugs, fishing boats, offshore service boats, displacement hull yachts, or short trip coastal freighters. Typical operation ranges from 2000 to 4000 hours per year.

Power at declared engine speed is in accordance with ISO3046-1:2002E. Caterpillar maintains ISO9001:1994/QS-9000 approved engine test facilities to assure accurate calibration of test equipment. Electronically controlled engines are set at the factory at the advertised power corrected to standard ambient conditions. The published fuel consumption rates are in accordance with ISO3046-1.

Fuel rates are based on fuel oil of 35° API [16°C (60°F)] gravity having an LHV of 42 780 kJ/kg (18,390 Btu/lb) when used at 29°C (85°F) and weighing 838.9 g/L (7.001 lb/U.S. gal). Additional ratings may be available for specific customer requirements. Consult your Caterpillar representative for additional information.

Performance data is calculated in accordance with tolerances and conditions stated in this specification sheet and is only intended for purposes of comparison with other manufacturers' engines. Actual engine performance may vary according to the particular application of the engine and operating conditions beyond Caterpillar's control.

Power produced at the flywheel will be within standard tolerances up to 50°C (122°F) combustion air temperature measured at the air cleaner inlet, and fuel temperature up to 52°C (125°F) measured at the fuel filter base. Power rated in accordance with NMMA procedure as crankshaft power. Reduce crankshaft power by 3% for propeller shaft power.

CAT, CATERPILLAR, their respective logos, ADEM, "Caterpillar Yellow," the "Power Edge" trade dress as well as corporate and product identity used herein, are trademarks of Caterpillar and may not be used without permission.

3512C



MARINE PROPULSION ENGINE

1359 mhp	(1340 bhp)	1000 bkW
1522 mhp	(1501 bhp)	1120 bkW
1597 mhp	(1575 bhp)	1175 bkW
1672 mhp	(1649 bhp)	1230 bkW



Image shown may not reflect actual engine

COMPLETE SOLUTIONS FOR YOUR MARINE APPLICATION

- Single-source for support and service
- Industry-leading warranty coverage for factory packaged components
- Global dealer network for service in any location

EFFICIENT OPERATION

- Instrument panel with cold mode start strategy and programmable low idle
- Electronic governing control unit minimizes fuel consumption and monitors engine operating parameters
- Optional alarm and protection system

IMPROVED PERFORMANCE AND FUNCTION

- Advanced combustion design uses the optimum configurations and cylinder geometry
- Enhanced control of fuel injection optimized through crank timing

ENVIRONMENTALLY CONSCIOUS

- Closed crankcase ventilation system and redesigned piston for improved efficiency and lower emissions
- Optimal nozzle geometry and electronic injection control for improved fuel delivery
- EPA Marine Tier 3/IMO Tier II Emissions Compliant

SPECIFICATIONS

V-12, 4-Stroke-Cycle-Diesel

- EPA Marine Tier 3 compliant
- IMO Tier II emissions compliant
- 58.56 L (3574 in³) displacement
- 1600 rpm
- 170 mm (6.69 in) bore x 215 mm (8.46 in) stroke
- Turbocharged-aftercooled aspiration
- Electronically governed A4 ECU
- Heat exchanger or keel cooled
- Refill capacity
 - Lube oil system: 613.2 L (162 gal)
- 1000-hour oil change interval
- Counterclockwise rotation
- SAE No. 00 flywheel and flywheel housing (183 teeth)
- Engine diagnostic system data link messaging

All new 3500C marine EPA Tier 3 capable engines, including both propulsion and auxiliary units, will be required to use a maximum concentration of 20% glycol mixture in the aftercooler circuit. This restriction applies equally to both heat exchanger cooled and keel cooled configurations (box coolers). In the event that specific project needs require higher levels of freeze protection, (lower freeze temperature), please contact ASC to review the specific engine rating and glycol concentration desired.

The jacket water circuit will continue to be capable of operation up to 50% glycol.

DIMENSIONS

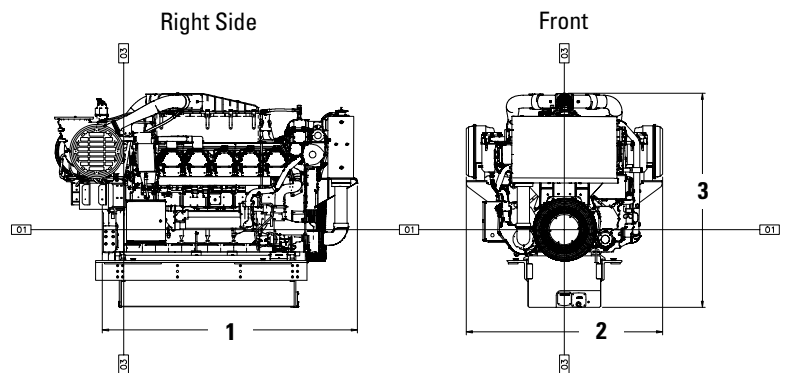

ENGINE DIMENSIONS & WEIGHT

(1) Length to Flywheel Housing	2645.4 mm	104.2 in
(2) Width	2036.6 mm	80.2 in
(3) Height	2222.6 mm	87.5 in
Weight, Net Dry (approx)	7488 kg	16,508 lb

Note: Do not use these dimensions for installation design. See general dimension drawings for detail (Drawing #420-1879). For complete information, please refer to the Marine Spec Sheet Wizard.

MARINE ENGINE PERFORMANCE

Max Power

rpm	A Rating				A Rating				B Rating				C Rating			
	bhp	g/hr	bkW	g/bkW-hr	bhp	g/hr	bkW	g/bkW-hr	bhp	g/hr	bkW	g/bkW-hr	bhp	g/hr	bkW	g/bkW-hr
1600	1341	67.0	1000	212.8	1502	74.6	1120	211.5	1576	77.9	1175	210.6	1649	81.3	1230	209.8
1300	1341	64.8	1000	205.9	1502	71.6	1120	203.1	1576	74.9	1175	202.5	1649	78.4	1230	202.3
1100	1341	61.9	1000	196.5	1415	65.2	1055	196.3	1542	71.2	1150	196.6	1542	71.2	1150	196.6
900	821	40.0	612	207.6	821	40.0	612	207.6	821	40.0	612	207.6	821	40.0	612	207.6
700	485	25.8	362	226.1	485	25.8	362	226.1	485	25.8	362	226.1	485	25.8	362	226.1
650	409	21.4	305	222.4	409	21.4	305	222.4	409	21.4	305	222.4	409	21.4	305	222.4

Prop Demand

rpm	A Rating				A Rating				B Rating				C Rating			
	bhp	g/hr	bkW	g/bkW-hr	bhp	g/hr	bkW	g/bkW-hr	bhp	g/hr	bkW	g/bkW-hr	bhp	g/hr	bkW	g/bkW-hr
1600	1341	67.0	1000	212.8	1502	74.6	1120	211.5	1576	77.9	1175	210.6	1649	81.3	1230	209.8
1300	719	36.0	536	213.1	806	40.6	601	214.3	845	42.8	630	215.6	885	45.0	660	216.8
1100	436	22.2	325	216.8	488	24.6	364	214.5	512	25.7	382	213.5	536	26.8	400	212.7
900	239	12.4	178	221.7	267	13.7	199	218.3	280	14.3	209	217.1	294	14.9	219	215.9
700	113	6.4	84	244.2	126	7.0	94	238.0	131	7.3	98	235.6	138	7.6	103	233.4
650	90	5.3	67	252.0	101	5.8	75	245.1	106	6.0	79	242.5	111	6.2	83	240.1

STANDARD ENGINE EQUIPMENT

- Corrosion-resistant aftercooler core
- Dual A4 engine control modules w/electronic unit injector fuel system
- Dual turbochargers with water-cooled bearings and heat shields
- Vibration damper and guard
- Closed crankcase ventilation system
- Thermostats and housing
- Electronically cooled unit injectors
- Engine oil cooler and oil filler
- Auxiliary fresh water pump
- Gear-driven, centrifugal jacket water pump
- Oil filter, oil level gauge, and oil pump

OPTIONAL ATTACHMENTS

- Plate-type heat exchanger
- Special appearance packages with chrome cover
- Marine society certifications
- Power takeoff
- Shutoff and alarm contactors
- SOLAS compliant fuel connections with spill shield
- Instrument panel with color Marine Power Display (MPD)
- Mounting rails
- Sea water pump
- See Marine Price List for additional attachments

RATING DEFINITIONS AND CONDITIONS

A Rating (Unrestricted Continuous)

Typical applications: For vessels operating at rated load and rated speed up to 100% of the time without interruption or load cycling (80% to 100% load factor). Typical applications could include but are not limited to vessels such as freighters, tugboats, bottom trawlers, or deep river tugboats. Typical operation ranges from 5000 to 8000 hours per year.

B Rating (Heavy Duty)

Typical applications: For vessels operating at rated load and rated speed up to 80% of the time, or 10 hours out of 12, with some load cycling (40% to 80% load factor). Typical applications could

include but are not limited to vessels such as mid-water trawlers, purse seiner, crew and supply boats, ferries, or towboats. Typical operation ranges from 3000 to 5000 hours per year.

C Rating (Maximum Continuous)

Typical applications: For vessels operating at rated load and rated speed up to 50% of the time, or 6 hours out of 12, with cyclical load and speed (20% to 80% load factor). Typical applications could include but are not limited to vessels such as ferries, harbor tugs, fishing boats, offshore service boats, displacement hull yachts, or short trip coastal freighters. Typical operation ranges from 2000 to 4000 hours per year.

CAT, CATERPILLAR, their respective logos, "Caterpillar Yellow" and the "Power Edge" trade dress, as well as corporate and product identity used herein, are trademarks of Caterpillar and may not be used without permission.

3512C



MARINE PROPULSION ENGINE

1835 mhp	(1810 bhp)	1350 bkW
1937 mhp	(1910 bhp)	1425 bkW
2039 mhp	(2011 bhp)	1500 bkW



Image shown may not reflect actual engine

COMPLETE SOLUTIONS FOR YOUR MARINE APPLICATION

- Single-source for support and service
- Industry-leading warranty coverage for factory packaged components
- Global dealer network for service in any location

EFFICIENT OPERATION

- Instrument panel with cold mode start strategy and programmable low idle
- Electronic governing control unit minimizes fuel consumption and monitors engine operating parameters
- Optional alarm and protection system

IMPROVED PERFORMANCE AND FUNCTION

- Advanced combustion design uses the optimum configurations and cylinder geometry
- Enhanced control of fuel injection optimized through crank timing

ENVIRONMENTALLY CONSCIOUS

- Closed crankcase ventilation system and redesigned piston for improved efficiency and lower emissions
- Optimal nozzle geometry and electronic injection control for improved fuel delivery
- EPA Marine Tier 3/IMO Tier II Emissions Compliant

SPECIFICATIONS

V-12, 4-Stroke-Cycle-Diesel

- EPA Marine Tier 3 compliant
- IMO Tier II emissions compliant
- 58.56 L (3574 in³) displacement
- 1600 rpm
- 170 mm (6.69 in) bore x 215 mm (8.46 in) stroke
- Turbocharged-aftercooled aspiration
- Electronically governed A4 ECU
- Heat exchanger or keel cooled
- Refill capacity
 - Lube oil system: 613.2 L (162 gal)
- 1000-hour oil change interval
- Counterclockwise rotation
- SAE No. 00 flywheel and flywheel housing (183 teeth)
- Engine diagnostic system data link messaging

All new 3500C marine EPA Tier 3 capable engines, including both propulsion and auxiliary units, will be required to use a maximum concentration of 20% glycol mixture in the aftercooler circuit. This restriction applies equally to both heat exchanger cooled and keel cooled configurations (box coolers). In the event that specific project needs require higher levels of freeze protection, (lower freeze temperature), please contact ASC to review the specific engine rating and glycol concentration desired.

The jacket water circuit will continue to be capable of operation up to 50% glycol.

DIMENSIONS

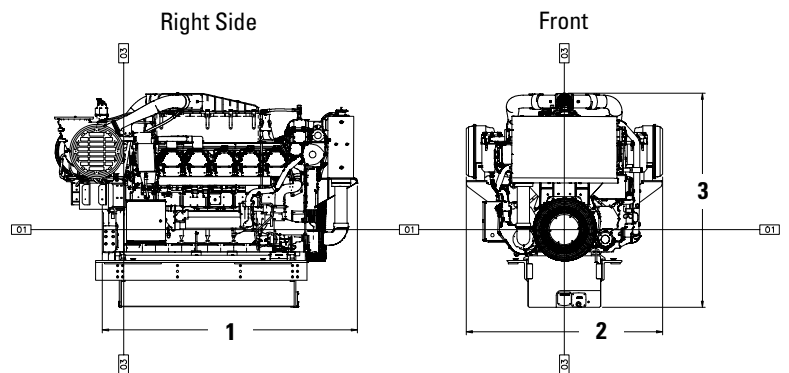

ENGINE DIMENSIONS & WEIGHT

(1) Length to Flywheel Housing	2645.4 mm	104.2 in
(2) Width	2036.6 mm	80.2 in
(3) Height	2222.6 mm	87.5 in
Weight, Net Dry (approx)	7488 kg	16,508 lb

Note: Do not use these dimensions for installation design. See general dimension drawings for detail (Drawing #420-1879). For complete information, please refer to the Marine Spec Sheet Wizard.

MARINE ENGINE PERFORMANCE

rpm	A Rating				B Rating				C Rating			
	bhp	g/hr	bkW	g/bkW-hr	bhp	g/hr	bkW	g/bkW-hr	bhp	g/hr	bkW	g/bkW-hr
1600	1810	88.7	1350	208.6	1911	93.5	1425	208.5	2012	98.6	1500	208.8
1300	1726	82.3	1287	203.1	1726	82.3	1287	203.1	1726	82.3	1287	203.1
1100	1609	74.4	1200	196.9	1609	74.4	1200	196.9	1609	74.4	1200	196.9
900	821	40.0	612	207.6	821	40.0	612	207.6	821	40.0	612	207.6
700	485	25.8	362	226.1	485	25.8	362	226.1	485	25.8	362	226.1
650	409	21.4	305	222.4	409	21.4	305	222.4	409	21.4	305	222.4

rpm	A Rating				B Rating				C Rating			
	bhp	g/hr	bkW	g/bkW-hr	bhp	g/hr	bkW	g/bkW-hr	bhp	g/hr	bkW	g/bkW-hr
1600	1810	88.7	1350	208.6	1911	93.5	1425	208.5	2012	98.6	1500	208.8
1300	971	49.9	724	218.9	1025	52.7	764	219.0	1080	55.0	805	217.2
1100	589	29.1	439	210.6	621	30.5	463	209.5	653	32.0	487	208.4
900	322	16.2	240	213.9	341	17.0	254	212.9	358	17.8	267	212.0
700	152	8.2	113	229.2	160	8.5	119	227.0	169	8.9	126	224.9
650	122	6.7	91	235.6	129	7.0	96	233.1	135	7.3	101	231.0

STANDARD ENGINE EQUIPMENT

- Corrosion-resistant aftercooler core
- Dual A4 engine control modules w/electronic unit injector fuel system
- Dual turbochargers with water-cooled bearings and heat shields
- Vibration damper and guard
- Closed crankcase ventilation system
- Thermostats and housing
- Electronically cooled unit injectors
- Engine oil cooler and oil filler
- Auxiliary fresh water pump
- Gear-driven, centrifugal jacket water pump
- Oil filter, oil level gauge, and oil pump

OPTIONAL ATTACHMENTS

- Plate-type heat exchanger
- Special appearance packages with chrome cover
- Marine society certifications
- Power takeoff
- Shutoff and alarm contactors
- SOLAS compliant fuel connections with spill shield
- Instrument panel with color Marine Power Display (MPD)
- Mounting rails
- Sea water pump
- See Marine Price List for additional attachments

RATING DEFINITIONS AND CONDITIONS

A Rating (Unrestricted Continuous)

Typical applications: For vessels operating at rated load and rated speed up to 100% of the time without interruption or load cycling (80% to 100% load factor). Typical applications could include but are not limited to vessels such as freighters, tugboats, bottom trawlers, or deep river tugboats. Typical operation ranges from 5000 to 8000 hours per year.

B Rating (Heavy Duty)

Typical applications: For vessels operating at rated load and rated speed up to 80% of the time, or 10 hours out of 12, with some load cycling (40% to 80% load factor). Typical applications could

include but are not limited to vessels such as mid-water trawlers, purse seiner, crew and supply boats, ferries, or towboats. Typical operation ranges from 3000 to 5000 hours per year.

C Rating (Maximum Continuous)

Typical applications: For vessels operating at rated load and rated speed up to 50% of the time, or 6 hours out of 12, with cyclical load and speed (20% to 80% load factor). Typical applications could include but are not limited to vessels such as ferries, harbor tugs, fishing boats, offshore service boats, displacement hull yachts, or short trip coastal freighters. Typical operation ranges from 2000 to 4000 hours per year.

CAT, CATERPILLAR, their respective logos, "Caterpillar Yellow" and the "Power Edge" trade dress, as well as corporate and product identity used herein, are trademarks of Caterpillar and may not be used without permission.